



United Process Valves

Tradition

Innovation

Commitment

GATE VALVES

GW & GS Series

WEDGE & SLAB GATE VALVES





HISTORY & MILESTONES

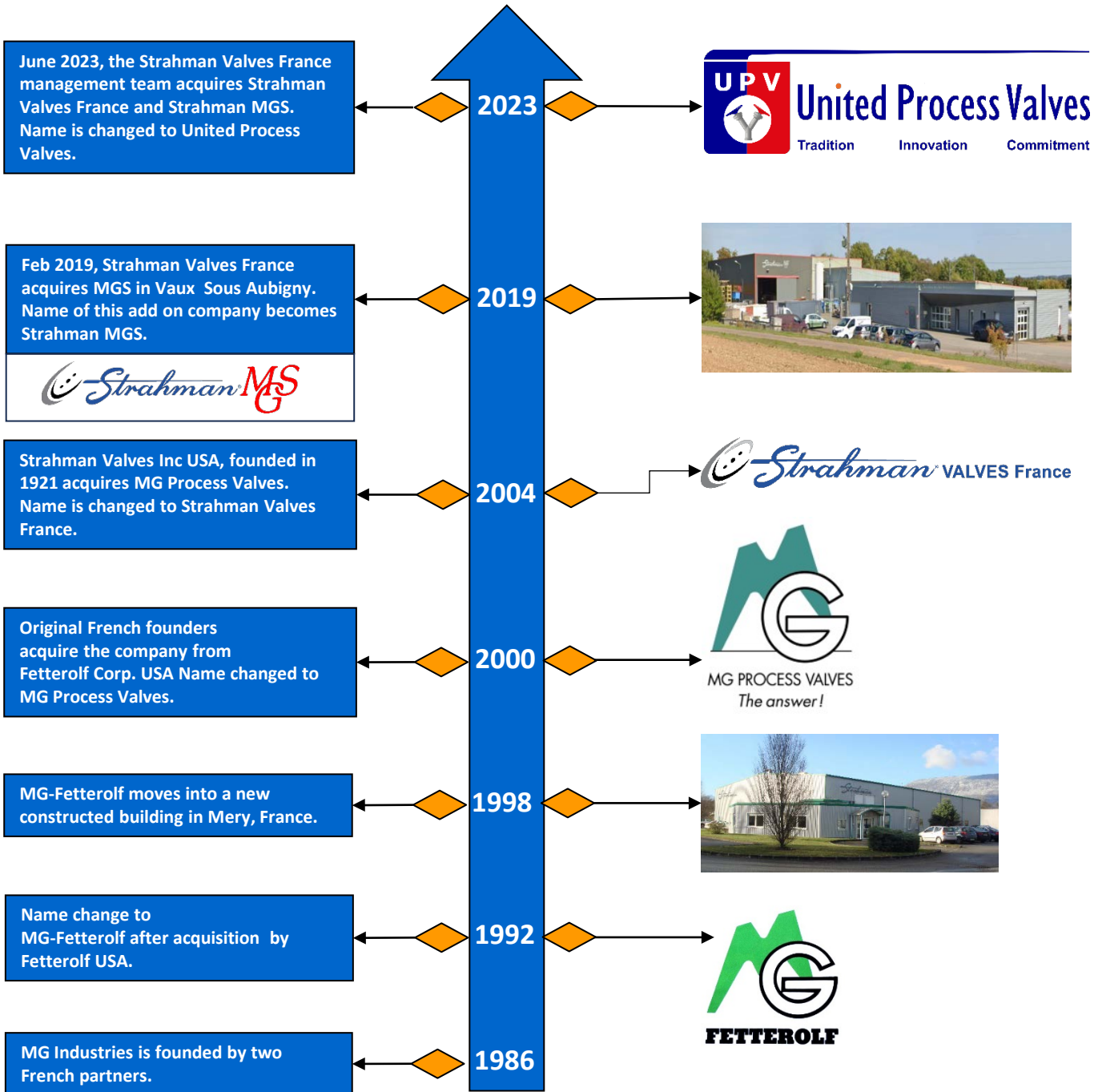



WEDGE GATE AND SLAB GATE VALVES FOR SPECIAL APPLICATIONS

Code: **GW2M**

Wedge gate Valves

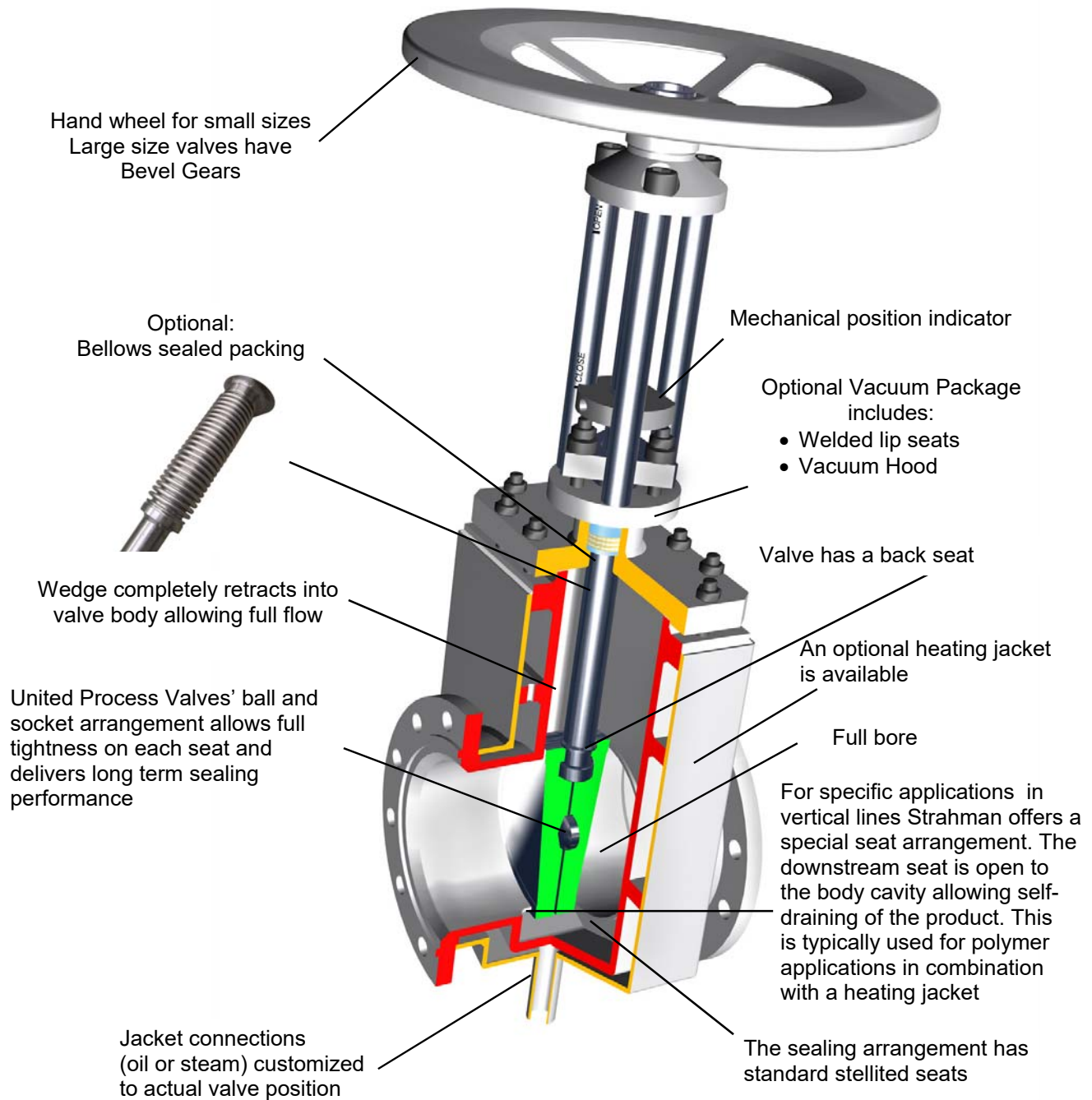

Fig. 060 / 065D



United Process Valves' designs and manufactures gate valves for special applications. They include specific applications where large diameters, jacketing or special materials are necessary. Most of Strahman's gate valves are customized to meet specific process requirements. They are well suited as isolation valves for process lines in chemical and petrochemical applications.

The safety of process equipment often depends on the reliability of these "key equipment" valves. The main features include tight shut-off, full bore design, availability of metal or resilient sealing arrangements and the choice between wedge or parallel seated designs. Jacketed wedge gate valves are mainly used in the polymer industry. Bellow-sealed wedge gate valves with welded lip seals are suitable for toxic and lethal products. Slab gate valves are recommended for isolation of ethylene furnaces where heavy feedstocks are cracked.

Wafer type Slab Gate Valve

Code: **GSD**

Slab Gate Valve with Dismountable Sleeve

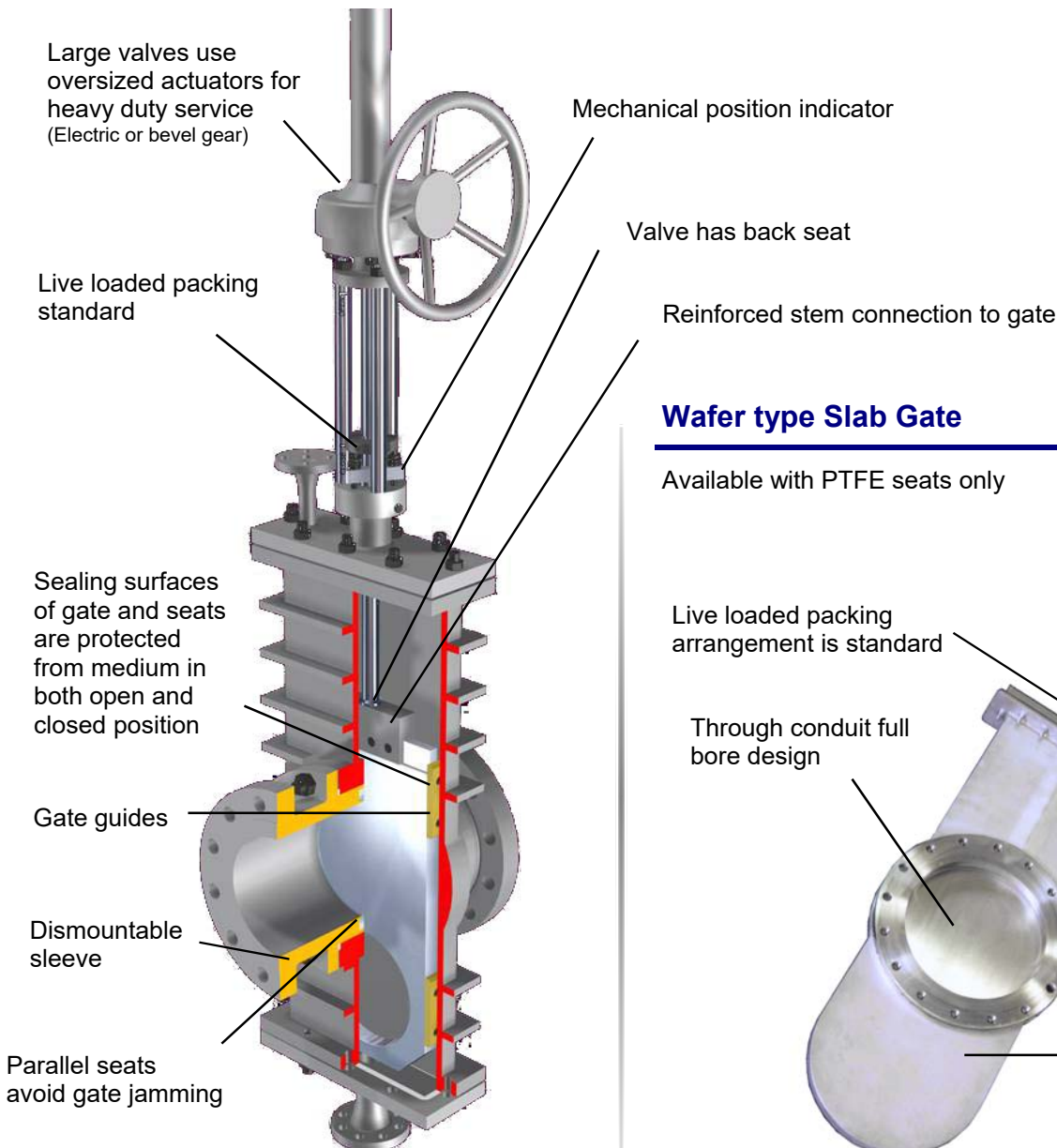

Fig. 074

Wafer type Slab Gate

Code: **GSD**

Available with PTFE seats only

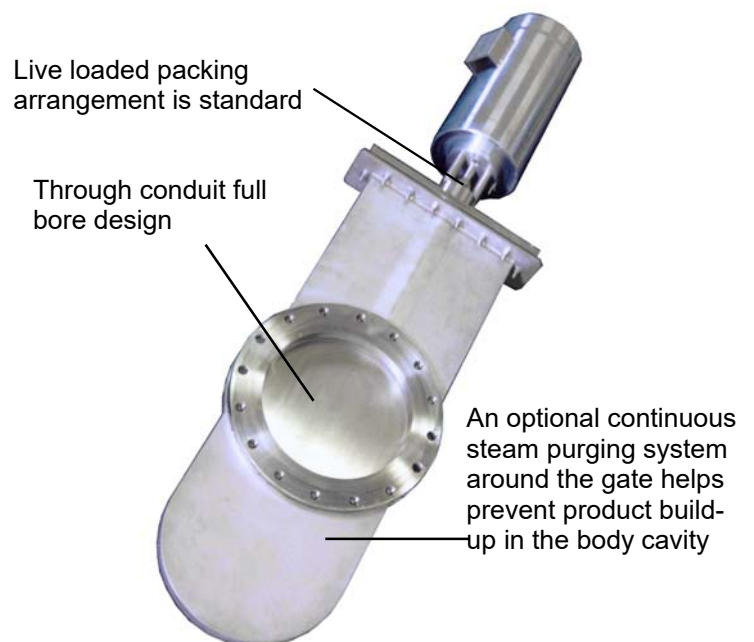

Fig. 072



BODY ARRANGEMENTS

United Process Valves Gate valves have three different configurations:

- Fig. 060 or 065 is for Wedge gate valves
- Fig. 072 is for Wafer type slab gate valves
- Fig. 074 is for Slab gate valves with dismountable seats

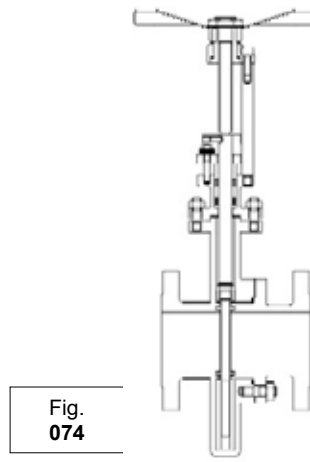
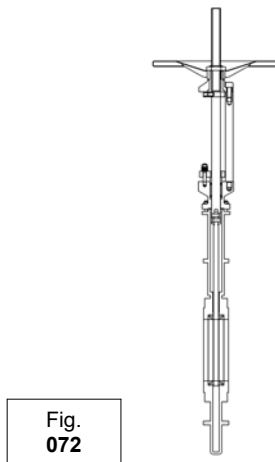
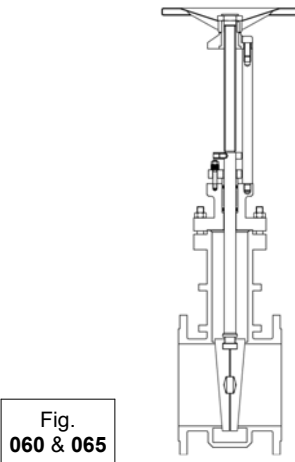

RANGE DEFINITION

GW Manufacturing Range	Manufacturing Range												
	PN 10	PN 16	PN 20-150 lbs.	PN 25	PN 40	PN 50 300 lbs.	PN64 400 lbs.	PN 100 600 lbs.	PN 150/160-900 lb	PN 250 -1500 lb	PN 320	PN 420-2500 lb	PN 630-4500 lb
3/8"- DIN10													
1/2"- DIN15													
3/4"- DIN20													
1"- DIN25													
1 1/4"- DIN32													
1 1/2"- DIN40													
2"- DIN50													
2 1/2"- DIN65													
3"- DIN80													
4"- DIN100													
5"- DIN125													
6"- DIN150													
8"- DIN200													
10"- DIN250													
12"- DIN300													
14"- DIN350													
16"- DIN400													
18"- DIN450													
20"- DIN500													
24"- DIN600													
28"- DIN700													
32"- DN800													
36"- DN900													
40"- DN1000													
44"- DN1100													
48"- DN1200													

Fig. 060 & 065

GS Manufacturing Range	Manufacturing Range												
	PN 10	PN 16	PN 20-150 lbs.	PN 25	PN 40	PN 50 300 lbs.	PN64 400 lbs.	PN 100 600 lbs.	PN 150/160-900 lb	PN 250 -1500 lb	PN 320	PN 420-2500 lb	PN 630-4500 lb
3/8"- DIN10													
1/2"- DIN15													
3/4"- DIN20													
1"- DIN25													
1 1/4"- DIN32													
1 1/2"- DIN40													
2"- DIN50													
2 1/2"- DIN65													
3"- DIN80													
4"- DIN100													
5"- DIN125													
6"- DIN150													
8"- DIN200													
10"- DIN250													
12"- DIN300													
14"- DIN350													
16"- DIN400													
18"- DIN450													
20"- DIN500													
24"- DIN600													
28"- DIN700													
32"- DN800													
36"- DN900													
40"- DN1000													
44"- DN1100													
48"- DN1200													

Fig. 072 & 074

Fig.074 Only



SEALING SYSTEMS

United Process Valves Gate Valve sealing systems utilize different designs for wedge and slab valves. The following drawings illustrate the specific differences.

Wedge

- Metal to Metal Gate to body seat sealing
- Stellite coating standard on body seat
- Bi-directional valve

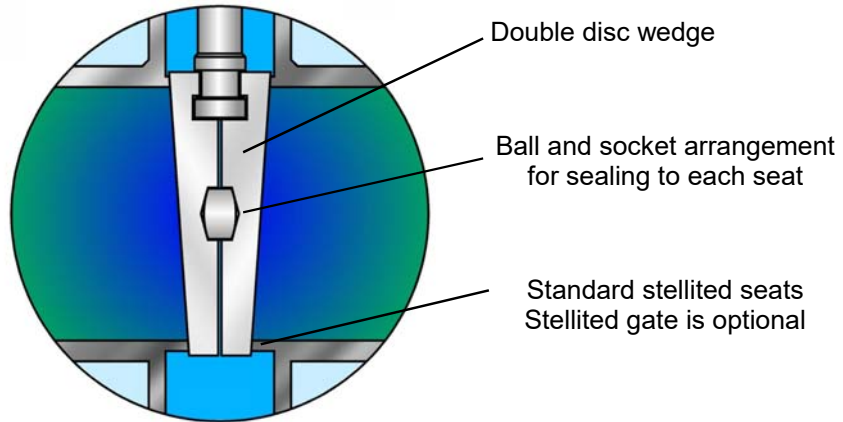

Resilient Seats with Scraper Ring

- Metal to resilient material Gate to seat sealing
- Bi-directional valve
- Replaceable seats

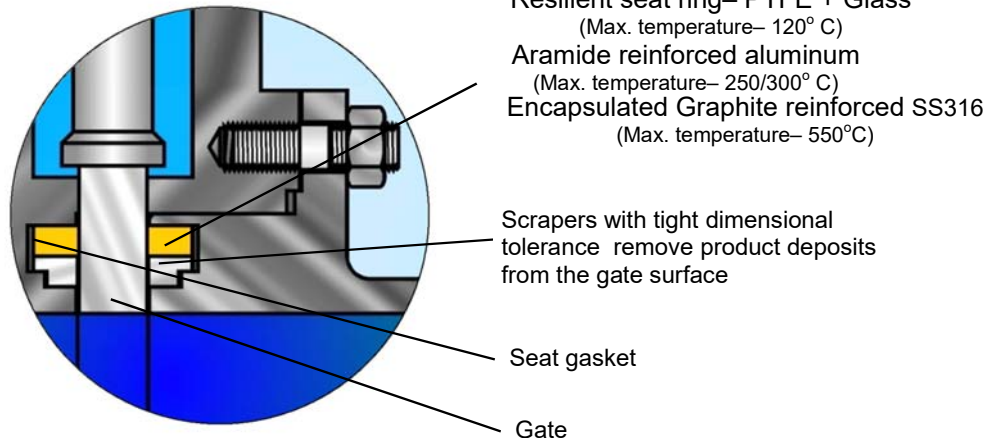

Resilient Seats with Scraper Ring

- Metal to resilient material Gate to seat sealing
- Bi-directional valve
- Replaceable seats

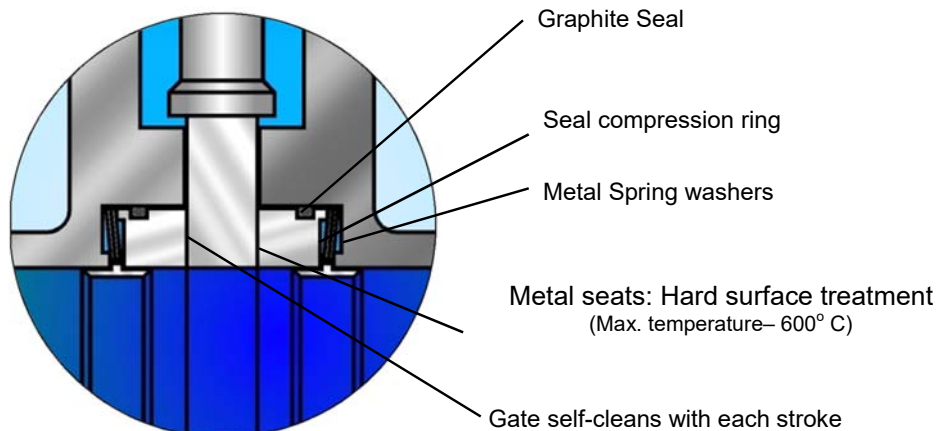

PACKING DEFINITION

Typical Packing Materials:

- PTFE
- PTFE / Aramide Braid
- Carbon / Graphite Braid
- Graphite Braid
- PTFE /Aramide Braid + Graphite
- Lamellar + Expanded Graphite
- Pure Graphite

Live loaded packing arrangement minimizes maintenance

Back seat arrangement is standard on this valve

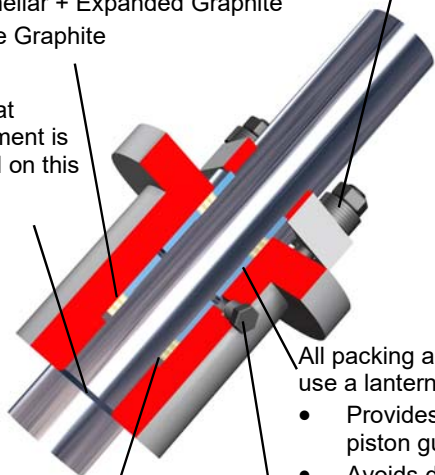

All packing arrangements use a lantern ring that:

- Provides better stem piston guiding
- Avoids dead space in body cavities

Bottom ring material is selected with a differential hardness from the piston to prevent piston damage

Optional 1/4 inch NPTF can be used for leak detection or inert gas injection to avoid leakage to atmosphere by creating an over pressure

VACUUM HOOD

For valves on full vacuum service United Process Valves offers a special **vacuum package** that maintains tightness to atmosphere. Valves with this package are usually equipped with an **M Ring Seal** design as process sealing. The system uses a replaceable aluminium or nickel seal ring and provides high vacuum performance. This special **vacuum package** provides zero leakage between atmosphere and process.

Viton or Graphite column gasket

Spring loaded secondary packing made of PTFE or Graphite

Vacuum hood gasket made of Aramide compound or Graphite

Live loaded packing arrangement is standard

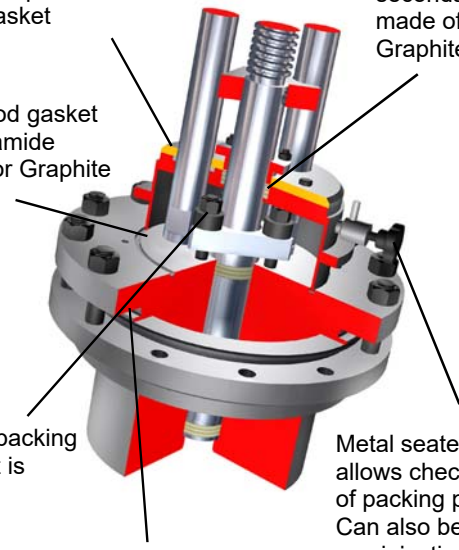

Metal seated test valve allows checking of packing performance. Can also be used for gas injection

Welded lip seals

STANDARD BODY GASKET RANGE

- PTFE
- Aramide / Nitrile
- Carbon / Aramide
- Laminated Graphite
- Laminated Graphite / 316
- Welded Lips

JACKET CONNECTIONS

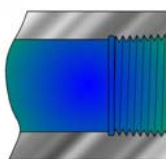
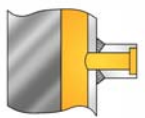
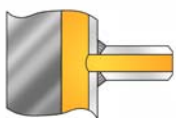

Flanges
ANSI, DIN, JIS

Butt Weld

Socket Weld

Threaded connections
NPT & BSP

Valve Coding System

G W 2 \$ W J

G Gate Valve	
W Wedge S Slab A Accessories	
2 Double Disc S Dismountable Sleeve D Dismountable Seat \$ Special	
S Soft Seated M Metal to Metal \$ Special	
F Flanged W Butt Weld A Wafer O Oversized Flange G Graylock \$ Special	
J Jacketed - Non-Jacketed	

NOTE: Some combinations may not be compatible



TECHNICAL & GENERAL INFORMATION

Design Code & Construction

- Design standard compliant with ASME B16.34
- International standards include ANSI, DIN, JIS, API etc.
- Wide range of material selections including carbon steel / stainless steel / Titanium / Hastelloy / Duplex / Monel / Tantalum / Zirconium
- Fabricated, cast, forged and bar stock designs
- Combinations of fabricated, sand and investment casings, and bar stock available

Surface Finish

- For polymer applications, United Process Valves recommends a surface facing of 300 (Ra 0.4) for all parts are in contact with the medium

Quality assurance & testing

- ISO 9001 compliant
- PED / ATEX / CE marking
- ISO 15848 1 & 2, low emission testing and certification available
- Standard testing procedures

LINE & BRANCH CONNECTIONS



Flanges
ANSI, DIN, JIS



Heated
Flanges

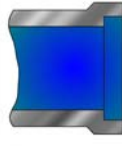

Socket
Weld

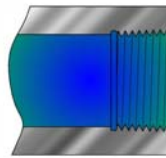

Threaded
connections
NPT & BSP

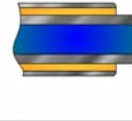

Butt
Weld

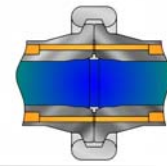

Fast Bolting Union
Graylock Securamax

ACTUATION OPTIONS



Hand Wheel



Bevel Gear



Electric Actuator



Air Motor



Double or single
acting Air Cylinder



Double or single acting Air
Cylinder with Safety Hand Wheel

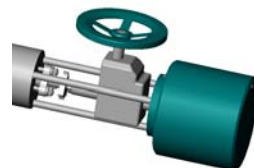

Double or single acting Air
Cylinder with side mounted
Safety Hand Wheel



Hydraulic
Cylinder



United Process Valves products include:

PISTON TYPE SAMPLING VALVES

United Process Valves has a full line of sampling valves that produce live samples without exception. Our sampling valves unique design prevents failure caused by sediment or clogging.

PISTON TYPE DRAIN VALVES

United Process Valves Drain Valves are designed to prevent clogging. They are ideal for use in liquid and gas services or with slurries, polymers, and high viscosity fluids that tend to solidify at room temperature.

PISTON & DISC TYPE IN-LINE VALVES

United Process Valves Piston and Disc Type In-Line Valves alternative to a failing ball, plug or gate valve. With a wide range of positive sealing systems like M Seal, M Ring Seal and M Control, these valves provide superior in-line tightness. When opening the piston or disc it retracts completely into the valve body providing an unrestricted full flow

PISTON & DISC TYPE DIVERTER VALVES

United Process Valves Diverter Valves are designed to divert process flows with high and low viscosity. They are dead space free to prevent clogging. They are ideal for use in liquid and gas services or with slurries, polymers, and high viscosity fluids that tend to solidify at room temperature.

SINGLE- & DOUBLE DISC SLAB GATE VALVES

United Process Valves Diverter Valves are designed to divert process flows with high and low viscosity. They are dead space free to prevent clogging. They are ideal for use in liquid and gas services or with slurries, polymers, and high viscosity fluids that tend to solidify at room temperature.

LINE BLINDS

United Process Valves Line Blinds provide zero leakage downstream and total isolation on process pipelines, vessels, and maritime applications. No pipeline movement is required when blind position is changed.

www.unitedprocessvalves.com

United Process Valves, France

136 rue Sommeiller, ZA Savoie Hexapole

F-73420, Mery, France

Tel: + 33 (0) 4 79 35 78 00

E-mail: upvsales@upvalves.com

United Process Valves, German Office

Allerheiligenstrasse 69

D-77855 Achern, Germany

Tel: +49 (0) 170 9766629

Shanghai United Process Valves Co.,Ltd. (UPV China)

Add: Building 1, No. 665 Jinbi Road, Jinhui Town,

Fengxian District, 201404, Shanghai - CHINA

Tel: +86 (0) 21-5713 3539

ISO 9001:2015

BUREAU VERITAS
Certification

